

Product Information

MR-008..025GM / K

Flow Switch MR



- High switching power
- Compact design

Characteristics

Mechanical flow switch, for fluid or gaseous media, with spring-supported piston and magnetic triggering of a reed switch. Robust construction in brass or stainless steel.

Technical data

Switch	reed switch	
Nominal width	DN 8.0.25	
Process connection	female thread G 1/4..G 1 (further process connections available on request)	
Switching range	0.4..60 l/min	for details see table "Ranges"
Pressure loss	0.4..1.9 bar at Q _{max.}	
Q_{max.}	to 80 l/min	
Tolerance	±5 % of full scale value	
Pressure resistance	PN 200 bar (with optional display O1 G 1/4..G 3/4 PN 90)	
Media temperature	-20..+120 °C	
Ambient temperature	-20..+70 °C	
Media	water (oils, gases and aggressive media available on request)	
Wiring	wiring no. 0.213	
Switching voltage	Max. 175 V DC / 120 V AC	
Switching current	Max. 0.25 A DC / 0.18 A AC	
Switching capacity	Max. 5 W / VA	
Protection class	2 - safety insulation	
Ingress protection	IP 65	
Electrical connection	cable 2.5 m (others cable lengths available on request)	
Materials medium-contact	Brass construction: CW614N nickelled, 1.4301, 1.4310, hard ferrite, NBR	Stainless steel construction: 1.4305, 1.4571, 1.4301, 1.4310, hard ferrite PTFE-coated, FKM
Non-medium-contact materials	PA, PVC	
Weight	see table "Dimensions and weights"	
Installation location	Standard: horizontal inwards flow from the left; other installation positions are possible; the installation position affects the switching point and range.	

Ranges

For switching ranges, the details in the table correspond to horizontal inwards flow and decreasing flow rate; for display ranges they correspond to horizontal inwards flow and increasing flow rate.

Switching range l/min H ₂ O	Optionally Display range l/min H ₂ O	Q _{max.} recommended	Pressure loss bar at Q _{max.} H ₂ O
0.4 - 4	0.5 - 5	10	0.4
1.0 - 10	1.0 - 12	20	0.9
5.0 - 20	5.0 - 25	30	0.7
10.0 - 40	5.0 - 40	60	1.9
20.0 - 60	20.0 - 60	80	1.6

Special ranges are available.

Dimensions and weights

	G	Types	X	Weight kg
Brass	G 1/4	MR-008GM	12	0.9
	G 3/8	MR-010GM		
	G 1/2	MR-015GM		
	G 3/4	MR-020GM	18	1.2
	G 1	MR-025GM		
Stainless steel	G 1/4	MR-008GK	12	0.9
	G 3/8	MR-010GK		
	G 1/2	MR-015GK		
	G 3/4	MR-020GK	18	0.8
	G 1	MR-025GK		

MR-008..020G.

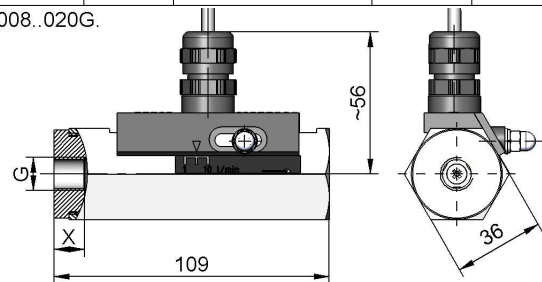

MR-025G.

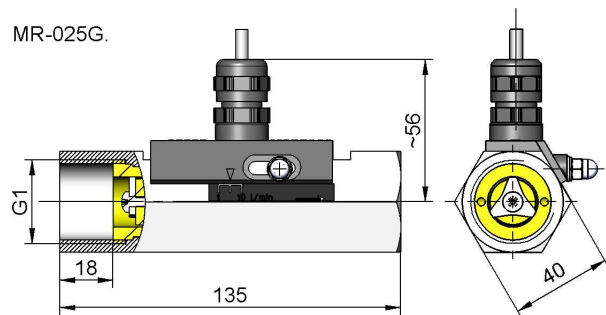

additional weights for options

Display O1 / Z1 0.04 kg

Product Information

MR-008..025GM / K

Handling and Operation

Note

- Install straight calming section of 5 x DN in inlet and outlet.
- Include a filter if the media are dirty (use magnetic filter for ferritic components).
- It must be ensured that the values given for voltage, current, and power are not exceeded.
- When switch on, a load must be connected in series.
- The electrical details apply to ohmic loads. Capacitive, inductive and lamp loads must be operated using a protective circuit.

Adjustment

If it is necessary to set the switching value, the switching head can be adjusted lengthways. When the switching value is reached, the switching unit is fixed in place by fastening bolts.

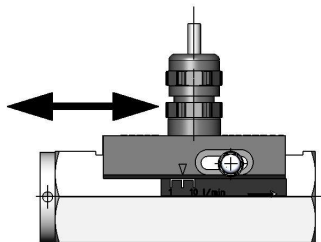

Ordering code

MR 1. 2. 3. **G** 4. 5.

1. Display options	
-	no mechanical display
O1-	with measurement display at side O1
2. Nominal width	
008	DN 8 - G 1/4
010	DN 10 - G 3/8
015	DN 15 - G 1/2
020	DN 20 - G 3/4
025	DN 25 - G 1
3. Process connection	
G	female thread
4. Connection material	
M	brass
K	stainless steel
5. Switching range H₂O for horizontal inwards flow	
004	0.4 - 4 l/min
010	1.0 - 10 l/min
020	5.0 - 20 l/min
040	10.0 - 40 l/min
060	20.0 - 60 l/min

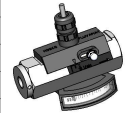

MRO1-

Options

- Switching values for oil or gas
- Special values
- Connection for round plug connector M12x1
- Additional switching head
- Damping for gas monitoring
- Switch contact SPDT change over 250 V AC 0.35A 30 VA - increased hysteresis depending on switching value. Only available with fixed switch point.
- Switch contact SPST N.O. 250 VDC 1.5 A 50 W / 265 VAC 1.1 A 50 VA

Ordering information

- Specify direction of flow, medium, and switching range.
- For viscous media specify viscosity, temperature, and medium (e.g. ISO VG 68) (enquire about switching range).
- For gases, state pressure (relative or absolute), temperature and medium (e.g. air) (request switching range).