

OPERATING MANUAL

TV125M / ST125M Universal Isolating Amplifier



umn_fam_sttv125m_vs1.41.en
07/2025



Table of Contents

1	Intended use (areas of application)	4
1.1	Safety signs and symbols.....	6
1.2	Safety instructions.....	6
1.3	Product liability and warranty	6
2	Product description	8
2.1	Scope of Delivery	8
2.2	Principle of operation	9
2.3	Layout of the measuring system	9
2.4	Block circuit diagram	10
2.5	Type label	11
2.6	Power Rail	12
3	Assembly and installation	13
3.1	Mechanical assembly.....	13
3.2	Electrical Installation.....	13
3.3	Connection Diagram.....	14
4	Operating steps, functional description, output	16
4.1	Operating steps, functional description.....	16
4.2	Status-LED.....	18
4.3	Output.....	19
4.4	Transmitter power supply (ST125, only).....	19
5	Commissioning, maintenance and service	20
5.1	Commissioning.....	20
5.2	Maintenance	20
5.3	Service.....	20
5.4	Error and system messages.....	21
6	Technical data	22
6.1	Safety-related key values.....	24
6.2	Mechanical design / dimensions.....	27

7	Accessories and replacement.....	28
8	Order code.....	28
9	Device transport and storage.....	29
10	Returns	29
11	Disposal	29
12	EU-Declaration of conformity.....	30

1 Intended use (areas of application)

Note

Refer to the chapter 2 *Product description* for detailed specifications for the area of application. The operational safety of the device is only assured when used as intended in accordance with the specifications in the operating manual. Intervention beyond the actions described in the operating manual may only be carried out by personnel authorised by the manufacturer for safety and warranty reasons.

Conversions or modifications made on one's own authority are expressly prohibited.

Danger!

Only device versions TV125M-Ex, TV125MP-Ex, ST125M-Ex and ST125MP-Ex are permitted for use as operating equipment for connection of intrinsically safe sensors, installed in Zones 0 or 1 and/or 20 or 21.

All safety-relevant characteristic data must be observed in this connection. (see **Fehler! Verweisquelle konnte nicht gefunden werden.** Fehler! Verweisquelle konnte nicht gefunden werden.)

Danger!

The approval for all intrinsically safe operating equipment is voided if it has been previously connected to non-intrinsically safe power circuit, because compliance with the safety-relevant characteristic data cannot be 100% guaranteed there.

Therefore, a safety test must be conducted by the manufacturer before later use as an intrinsically safe operating device.

Danger!

The device TV125MP-00, ST125MP-00 and all other versions of the series TV****-Ex and ST****-Ex can be installed in the explosion-prone Zone 2 under the following conditions:

- ▶ Installation in a clean environment in a conductive, earthed housing (switch cabinet) with a minimum protection rating of IP54.
- ▶ Disconnection of connecting terminals only takes place in the de-energised state

Standards:: EN 60079-0 und EN 60079-7

General safety instructions, use

This operating manual must be kept in a location such that qualified personnel can refer to it at all times. Any processes described in this operating manual may only be carried out by trained, qualified personnel who are authorised by the owner and wearing protective clothing. All rights reserved.

1.1 Safety signs and symbols

Warning notices are identified in this document as described under **Fehler! Verweisquelle konnte nicht gefunden werden.**:

Danger!

This symbol warns of imminent danger which can result in death, severe bodily injury, or severe property damage in case of non-observance

Caution!

Attention! This symbol warns of potential dangers or harmful situations which can cause damage to the device or to the environment in case of non-observance.

Note

Blue underlining indicates processes which can have a direct influence on operation or can trigger an unforeseen reaction in case of non-observance.

1.2 Safety instructions

Danger!

Read the product description before commissioning the device. Ensure that there are no limitations for use of the product for the relevant applications. The owner is responsible for ensuring the fault-free operation of the device. The owner is obligated to ensure compliance and to observe the required work and safety measures of the current applicable regulations for the entire duration of use.

1.3 Product liability and warranty

Exclusion of liability:

The contents of the operating manual have been checked to ensure conformity with the described device. However, deviations cannot be entirely ruled out. Therefore, we cannot assume any guarantee for complete conformity. The specifications in this document are checked regularly and any necessary corrections are incorporated into subsequent versions. This document is subject to technical changes. In addition, all claims are based on the valid 'Standard Terms for the Supply of Products and Services of the Electrical Industry'.

Note

Senseca Germany cannot inspect or repair any devices without the required form having been filled in completely (see 10 Returns)

2 Product description

Isolating amplifiers of the series TV/ST125 are suitable for potential isolation and for conversion of unit signals - optionally in explosion-prone environments. The universal configuration of the input, output and internal power supply by means of a wide-range mains adapter limits the number of models to a few versions. The auxiliary voltage supply can be optionally provided by means of a mounting rail bus connector.

The input measuring range can be switched between

0...20 mA and 4..20 mA and/or

0...10 V and 2...10 V

on the front side via a DIP switch.

The output measuring range can be configured between

0...20 mA and 4..20 mA and/or

0..10 V and 2..10 V

on the front side via a DIP switch.

With the microprocessor-controlled measurement recording, undercutting and exceeding of measuring ranges are detected and communicated via a two-colour status LED on the front side. Then the output is set to a defined starting value and/or end value.

The starting value and the end value of the measuring range can be adjusted with the two trimmers on the front side.

The device version ST125 provides an additional transmitter feed for external 2, 3- wire sensors.

The devices can also be used in the explosion-prone Zone 2 if they are installed in a suitable housing.

Use in systems with functional safety SIL2 is also possible.

2.1 Scope of Delivery

- TV125M or ST125M, according to ordering code
- Power Rail DIN rail adapter (available for LP version, only)
- this operating manual
- further document if applicable

2.2 Principle of operation

The input signals are amplified in the input stage, the amplitudes are limited and the band is limited with an analogue filter of the third order. The filtered signal is digitalised by the analogue-digital converter of the microprocessor with a resolution of 14 bits. After scaling and a measuring range check, the signal is transmitted by means of pulse width modulation via an optocoupler to the output stage.

The output stage converts the PWM signal to a proportional analogue value which is then output via the output. The output current and/or output voltage are limited to a defined starting value and/or end value.

The three circuits: Input, output and auxiliary voltage are galvanically isolated with amplified isolation.

2.3 Layout of the measuring system

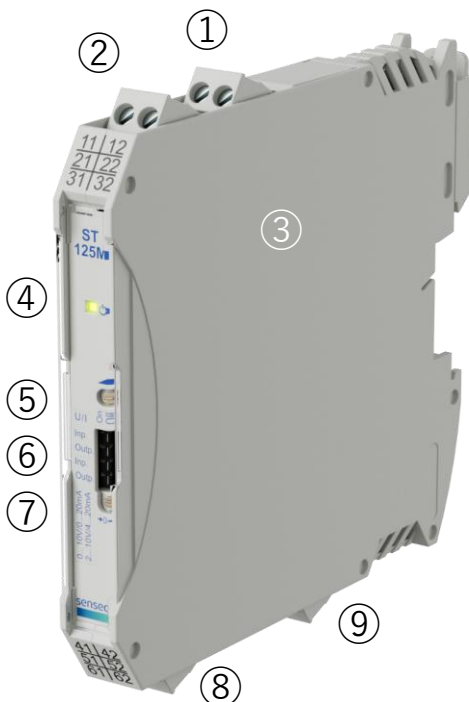

①	Terminals for auxiliary voltage
②	Terminals for current output
③	Type plate / connection diagram
④	Status-LED
⑤	Trimmer for end value adjustment
⑥	DIP-switches for configuration of in / output
⑦	Trimmer for starting value adjustment
⑧	Terminals for transmitter power supply
⑨	(ST125M, only)

Table 1 Legend "Layout of measuring system"

Figure 1 Isolating amplifier TV125M

2.4 Block circuit diagram

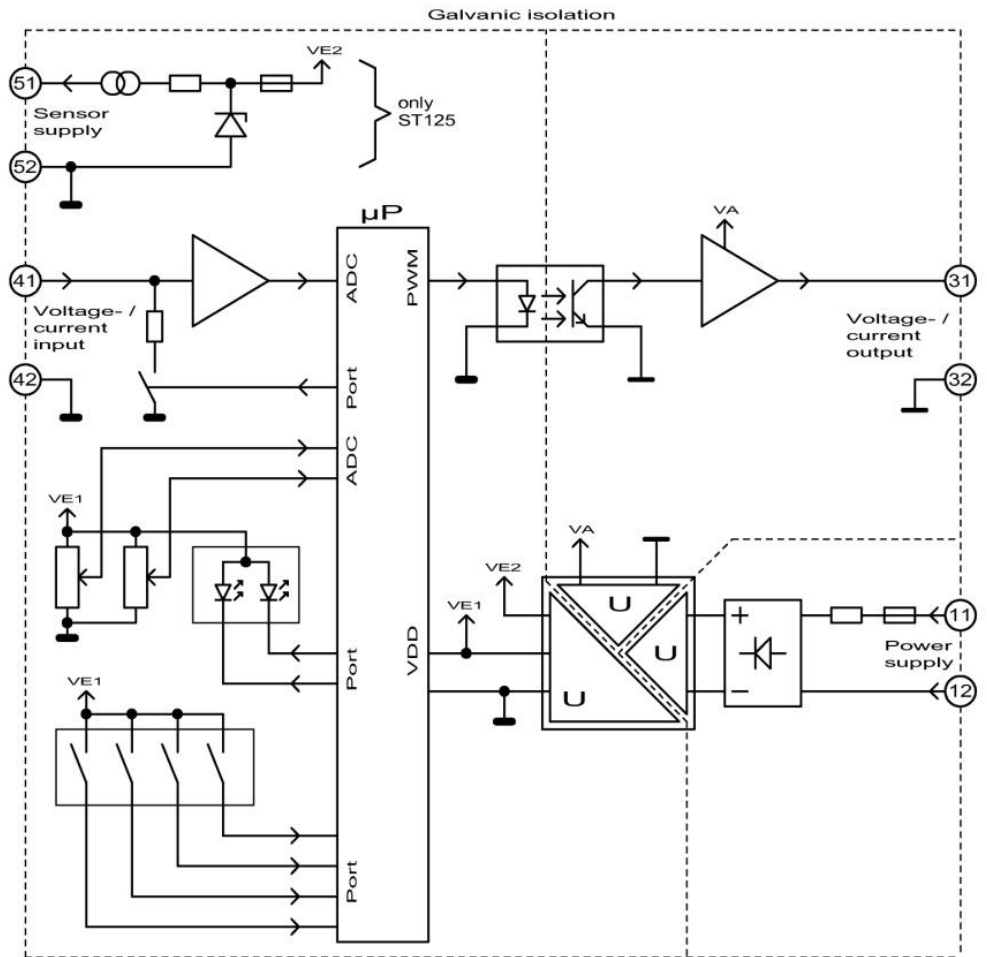

Figure 2 Block circuit diagram

2.5 Type label

The type plate contains the most important identification data:

- Connection diagram
- Manufacturer
- Type and article description
- Technical specifications
- Serial number / barcode

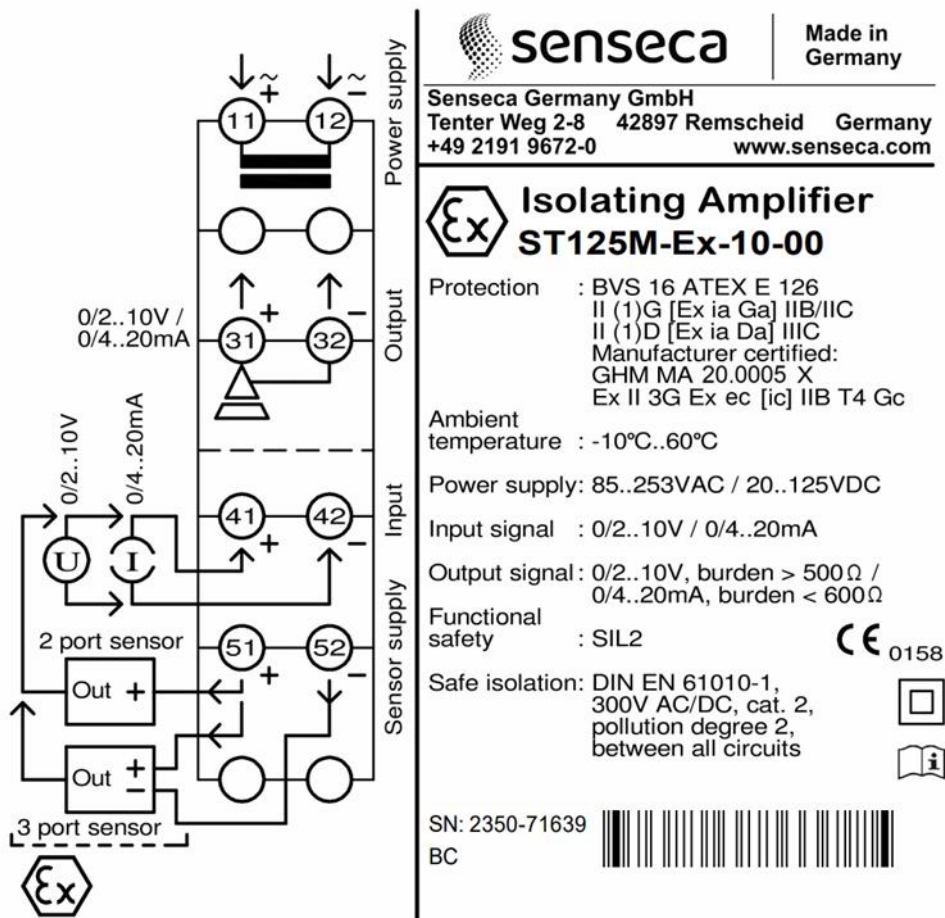

Figure 3 Type Plate

2.6 Power Rail

The supply of multiple devices can be combined and simplified via a bus system in the carrier rail (TS35).

A corresponding version is available for the entire LP series of our rail devices in a housing with 12.5 mm width.

A bus adapter compatible with series connection is clamped on the carrier rail before installation of the device to be supplied with power. An adapter is required for each device. The bus power supply is provided via a plug-type terminal strip PRVK.

The power supply terminals 11 and 12 on the upper device side are omitted in device version ST/TV125MP designed for this purpose.

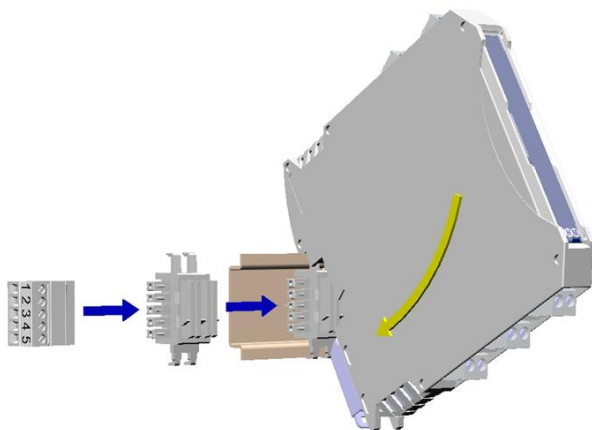

Figure 4 Example: TV125MP with DIN rail connector and supply terminal PRVK (optional accessories)

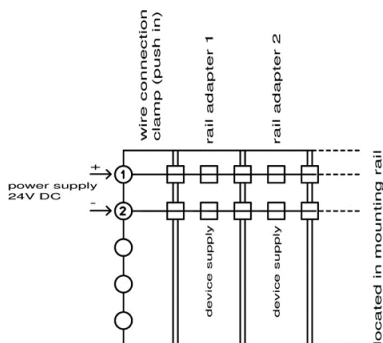

Figure 5 Terminal assignment PRVK

3 Assembly and installation

3.1 Mechanical assembly

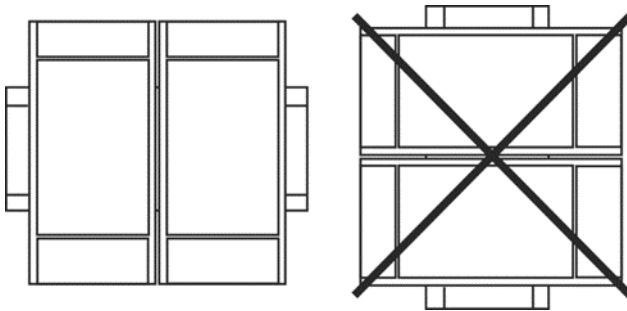

Figure 6 Rail mounting TH35

The installation of multiple devices without spacing is only permitted with a horizontally mounted DIN rail.

3.2 Electrical Installation

Danger!

The device may only be installed by a qualified electrician. The national and international regulations for the installation of electrical systems of the respective operator country apply.

Power supply according to DIN EN 60664-1.

SIL 2 requires an EMC-adequate installation, according to EN 60204-1 (for example). Connection of the auxiliary voltage takes place at connections 11 and 12 of the plug-in terminal strip.

Terminals 41 and 42 are intended for the input and terminals 51 and 52 are for the transmitter feed.

The active analogue output is provided at terminals 31 and 32.

There are two DIP switches in the front panel for configuration of the input measuring range and the output range.

The starting value and the end value of the measuring range can be adjusted with the two trimmers on the front side.

Electrical Connections

Terminal	Assignment
11	Supply voltage ~/+
12	Supply voltage ~/-
31	Analogue output + 0/4...20 mA or 0/2...10 V
32	Analogue output - 0/4...20 mA or 0/2...10 V
41	Analogue input + 0/4...20 mA or 0/2...10 V
42	Analogue input - 0/4...20 mA or 0/2...10 V
51	Transmitter power supply + > 15 V (characteristic, see section 4.4)
52	Transmitter power supply - > 15 V (characteristic, see section 4.4)

Table 2 Electrical connections

3.3 Connection Diagram

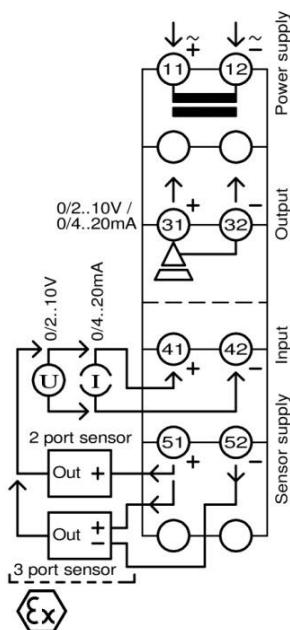

Auxiliary voltage:	85...253 VAC / 20...125 VDC or 24 VDC +/- 15%
Output: :	0/2...10 V oder 0/4...20 mA
Input:	0/2...10 V oder 0/4...20 mA
Transmitter power supply	(ST125, only)

Table 3 Description electrical poerties

Figure 7 Connection diagram ST125M / TV125M

Connecting signal source

<p>2-wire 0/4...20 mA source, loop powering</p> 	<p>3-wire source, loop powering</p> 	<p>4-wire source, loop powering</p> 
<p>2-wire 0/4...20 mA source, external loop power</p> 	<p>3-wire source, external loop power</p> 	<p>2-/4-wire sourcer, external loop power (active)</p> 

Table 4 ST125M/TV125M wiring examples

4 Operating steps, functional description, output

4.1 Operating steps, functional description

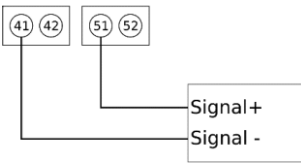
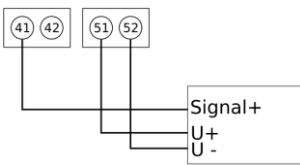
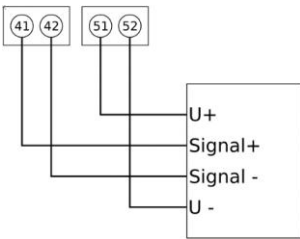
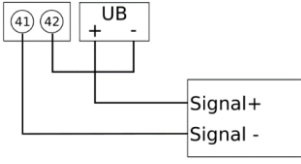
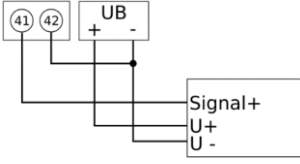
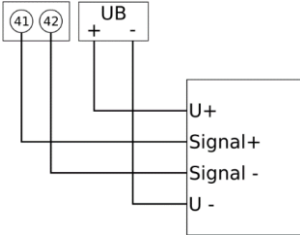
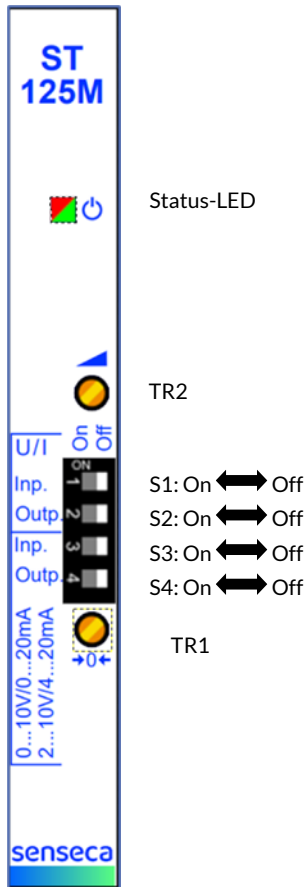

Status LED	Description
Green LED illuminates	Operating voltage connected
Red or green LED blinks	See 4.2 Status-LED
Red LED illuminates (> 2 s)	See 4.2 Status-LED

Table 5 Status-LED

Trimmer	Adjustment
TR1	Starting value
TR2	End value

Table 6 Trimmer

Figure 8 Front plate

Selection of signal type for in- / output

DIP-switches	On	Off
S1	Input configuration as voltage input	Input configuration as current input
S2	Output configuration as voltage output	Output configuration as current output

Table 7 DIP-switches S1 and S2

Selection of live-zero

DIP-switches	On	Off
S3	Input configuration: S1 = On: 0 ... 10 V, S1 = Off: 0 ... 20 mA	Input configuration: S1 = On: 2 ... 10 V, S1 = Off: 4 ... 20 mA
S4	Output configuration: S2 = On: 0 ... 10 V, S2 = Off: 0 ... 20 mA	Output configuration: S2 = On: 2 ... 10 V, S2 = Off: 4 ... 20 mA

Table 8 DIP-switches S3 and S4

Configuration matrix

Configuration	S1	S2	S3	S4	Input	Output
1	Off	Off	Off	Off	4 ... 20 mA	4 ... 20 mA
2	Off	Off	Off	On	4 ... 20 mA	0 ... 20 mA
3	Off	Off	On	Off	0 ... 20 mA	4 ... 20 mA
4	Off	Off	On	On	0 ... 20 mA	0 ... 20 mA
5	Off	On	Off	Off	4 ... 20 mA	2 ... 10 V
6	Off	On	Off	On	4 ... 20 mA	0 ... 10 V
7	Off	On	On	Off	0 ... 20 mA	2 ... 10 V
8	Off	On	On	On	0 ... 20 mA	0 ... 10 V
9*	On	Off	Off	Off	2 ... 10 V	4 ... 20 mA
10	On	Off	Off	On	2 ... 10 V	0 ... 20 mA

Configuration	S1	S2	S3	S4	Input	Output
11	On	Off	On	Off	0 ... 10 V	4 ... 20 mA
12	On	Off	On	On	0 ... 10 V	0 ... 20 mA
13	On	On	Off	Off	2 ... 10 V	2 ... 10 V
14	On	On	Off	On	2 ... 10 V	0 ... 10 V
15	On	On	On	Off	0 ... 10 V	2 ... 10 V
16	On	On	On	On	0 ... 10 V	0 ... 10 V

Table 9 DIP-switches, configuration

* Default-Einstellung

4.2 Status-LED

In error-free operation the front-side two-colour status LED illuminates green.

When there is an error, the status LED issues a blinking sequence consisting of a specific number of green and red light pulses:

Error circuit	Blinking sequences		Cause
	Green	Red	
System	0	1	Electronic defective
Auxiliary voltage	0	1	Supply voltage of the processor is too low
	0	1	Auxiliary voltage < 18V
Input	2	1	Under-modulation (< -0.3mA / -0.15V or < 3.7mA / 1.85V)
	2	2	Over-modulation (> 20.8mA or > 10.4V)
Output	3	1	Under-modulation (< -0.2mA / -0.1V or < 3.8mA / 1.9V)
	3	2	Over-modulation (> 20.5mA or > 10.25V)

Table 10 Status message

4.3 Output

Behaviour of the output when a range is undercut and exceeded:

Output	Modulation range	Under-modulation	Over-modulation
0...10 V	-0,1...10,25 V linear	-0,2 V	10,5 V
2...10 V	1,9...10,25 V linear	1,8 V	10,5 V
0...20 mA	-0,2...20,5 mA linear	-0,4 mA	21 mA
4...20 mA	3,8...20,5 mA linear	3,6 mA	21 mA

Table 11 Modulation range

4.4 Transmitter power supply (ST125, only)

Characteristic curve and output data (terminals 50 and 51):

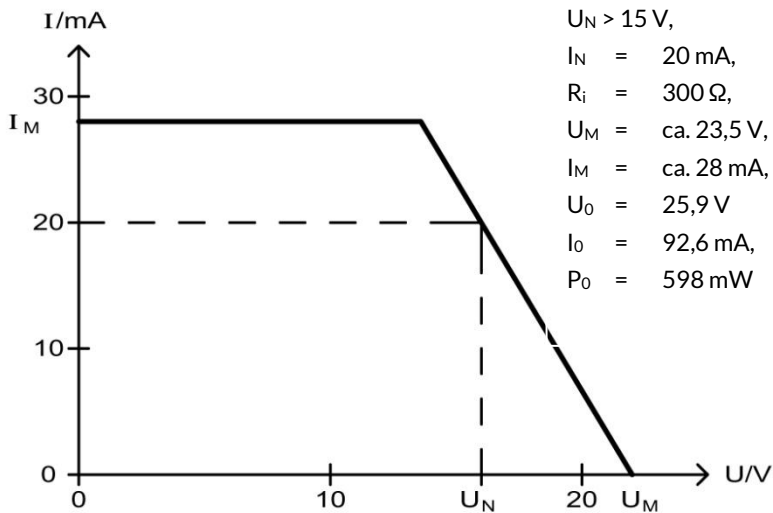

Figure 9 Transmitter power supply, characteristic curve

5 Commissioning, maintenance and service

5.1 Commissioning

- 1 Ensure that the connections have been made as indicated in the connection diagram and the auxiliary voltage is correct.
- 2 When connecting operating equipment from explosion-prone areas, ensure that the device version has the appropriate approval.
- 3 When installing the isolating amplifier in Zone 2, the device must be installed in a switch cabinet with protection rating IP54.
- 4 Make sure that the terminals are firmly screwed in.
- 5 After switching on the auxiliary power, check to ensure the correct configuration.

Note

After the auxiliary voltage is connected, a check of the device function takes place according to the requirement for functional safety.

The device is ready for operation after approx. 3 seconds.

The functional test also includes a load test of the auxiliary voltage. The device is subjected to the equivalent of a maximum load for a period of 2 seconds, i.e. a short circuited sensor supply and an output current of 21 mA at the output. The load is only simulated, which means the sensor supply is not short-circuited internally and the output current of the output is 0 mA.

5.2 Maintenance

Housing

When used as intended, no cleaning or maintenance is required.

5.3 Service

Note

Service of the device is only possible in the factory.

5.4 Error and system messages

Error	Causes	Remedy
Status-LED not illuminated	<ul style="list-style-type: none"> • Plug-in terminal strip of the auxiliary voltage input not plugged in. 	<ul style="list-style-type: none"> ▶ Check the plug-in terminal strip for firm seating
	<ul style="list-style-type: none"> • Electronics defective. 	<ul style="list-style-type: none"> ▶ Failure of the unit, please return to manufacturer!
Red LED blink	<ul style="list-style-type: none"> • Auxiliary voltage < 18 V. 	<ul style="list-style-type: none"> ▶ Test auxiliary voltage at Terminal 11 and 12
	<ul style="list-style-type: none"> • Electronics defective. 	<ul style="list-style-type: none"> ▶ Failure of the unit, please return to manufacturer!
Red and green LEDs blink alternately		
2 x green, 1 x red	<ul style="list-style-type: none"> • Under-modulation input < -0,3 mA / -0,15 V resp. < 3,7 mA / 1,85 V 	<ul style="list-style-type: none"> ▶ Check the plug-in terminal strip for firm seating. ▶ Check for open circuit. ▶ Check auxiliary voltage. ▶ Check signals source. ▶ Adjust start value.
x green, 2 x red	<ul style="list-style-type: none"> • Over-modulation input > 20,8 mA resp. > 10,4 V 	<ul style="list-style-type: none"> ▶ Check for short circuit. ▶ Check signals source. ▶ Adjust end value.
3 x green, 1 x red	<ul style="list-style-type: none"> • Under-modulation output < -0,2 mA / -0,1 V resp. < 3,8 mA / 1,9 V 	<ul style="list-style-type: none"> ▶ Check the plug-in terminal strip for firm seating. ▶ Check for open circuit. ▶ Check auxiliary voltage. ▶ Check signals source. ▶ Adjust start value.
3 x green, 2 x red	<ul style="list-style-type: none"> • Over-modulation output > 20,5 mA resp. > 10,25 V 	<ul style="list-style-type: none"> ▶ Check for short circuit. ▶ Check signals source. ▶ Adjust end value.

Table 12 Error and system messages

6 Technical data

Power Supply	
Supply Voltage ST/TV125M ST/TV125MP	20...125 V DC and 20...250 V AC (47...63Hz) 24 V DC
Power consumption Wide-range power supply ST/TV125M Power Rail ST/TV125MP	< 4 VA < 2 W
Data for all device types	
Rated voltage U_m	300V AC/DC degree of contamination 2, overvoltage category II, safe separation with increased isolation).
Ex-ia-operation	253V AC / 125V DC
Test voltage	3 kV AC (Input / Output / Supply voltage)
Ambient conditions	
Working temperature	-10...60 °C
Storage temperature	-20...80 °C
Air humidity, relative	10...90 %
Condensation	Not allowed
Maximum operating height above sea level	≤ 2000 m
Conformity	CE
Functional safety	EN 61508-1...5 SN 29500
Input signals	
Voltage input	0...10 V or 2...10 V, selectable $R_i = 30 \text{ k}\Omega$. Overload 26 V DC, max.
Current input	0...20 mA or 4...20 mA selectable. $R_i = 51 \Omega$. Overload 113 mA, max.
Measuring span	adjustable $\pm 2\%$ with 12-step-trimmer
Zeropoint	adjustable $\pm 2\%$ with 12-step-trimmer

Transmitter power supply (ST125, only) Nominal voltage at 20 mA current output A	> 15 V @ terminals 51, 52. > 14 V @ terminals 51, 41. $R_i = 300 \Omega$. (characteristic, see section 4.4)
Output signals	Current- or voltage input, selectable
Voltage output	0...10 V or 2...10 V selectable, Load > 500 Ω
Current output	0...20 mA or 4...20 mA selectable, Load < 600 Ω
Step response T90	40ms
Standard error	< 0,2 % of end value
Temperature coefficient	< 0,01 % / K
Housing	
Material	Polyamide (PA) 6.6, UL94V-0
Color	Light grey
Installation width	12,5 mm
Dimensions (HxT)	108 x 114 mm
Weight	91 g
Protection rating	Housing IP 30, terminals IP 20 BGV A3
Connection type	
Screw terminals	0,2...2,5 mm ² , AWG 24..14, removable, coded. Wire stripping length: 8mm Tightening torque: 0,5...0,6 Nm
Push-In-terminals (spring loaded)	0,5..1,5 mm ² , AWG 25..16, double connection (12A between connections), removable, coded.
Power Rail	8A over the entire bus system (Supply via removable terminals) 0,2..2,5 mm ² , AWG 24..14)
Mounting	DIN Rail mounted, TH35

Table 13 Technical data

6.1 Safety-related key values

Functional safety SIL2 (parameters acc. to EN61508 and SN29500)

Level	SIL 2 (Parameters acc. to EN 61508 and SN 29500) for Input type 4...20 mA or 2...10 V and Output type 4...20 mA or 2...10 V.
Device type	B
HFT	0 (1oo1)
Error signaling	Output 0 V resp. 0 mA
Reaction time	
Standard mode→error	40 ms
Error→Standard mode	1 s (self resetting)
Evaluation criteria for supply voltage drops to 0 % over 20 ms.	

Table 14 Parameters acc. to EN61508; SN29500

MTBF-calculation acc. to SN29500

Device	TV125M	TV125MP	ST125M	ST125MP
λ_{SD} [FIT]	8,37E-08	8,37E-08	8,64E-08	8,64E-08
λ_{SU} [FIT]	2,42E-07	2,27E-07	2,69E-07	2,53E-07
λ_{DD} [FIT]	3,75E-07	3,60E-07	4,23E-07	4,08E-07
λ_{DU} [FIT]	2,52E-08	2,52E-08	2,52E-08	2,52E-08
SFF [%]	96,5	96,4	96,9	96,7
DC [%]	93,7	93,5	94,4	94,2
PFH [1/h]	7,26E-07	6,95E-07	8,04E-07	7,73E-07
PFDavg				
1 years	3,18E-03	3,05E-03	3,52E-03	3,39E-03
2 years	6,36E-03	6,09E-03	7,04E-03	6,77E-03
2,5 years	7,95E-03	7,62E-03	8,80E-03	8,47E-03

Table 15 MTBF key values

Technical data for use in potentially explosive atmospheres

Marking, explosion protection: Devices with intrinsically safe input, zone 0/1	
Device type Certificate BVS 16 ATEX E 126	TV125M*-Ex, ST125M*-Ex Ignition type „ia“ Gas : II (1) G [Ex ia Ga] IIC/IIB Dust : II (1) D [Ex ia Da] IIIC
Manufacturer´s certificate	Ignition type „ic“ II 3 G Ex ec [ic] IIB T4 Gc Operating conditions for Zone 2 installation, see 1 Intended use (areas of application).
Marking, explosion protection: Devices without intrinsically safe input	
Device type Manufacturer´s certificate	TV125MP-00, ST125MP-00 Ignition type „ec“ II 3 G Ex ec IIB T4 Gc Operating conditions for Zone 2 installation, see 1 Intended use (areas of application).
ATEX limit value input circuit (input) Terminals 41(+) and 42(-)	
Output-voltage	U ₀ 27,6 V
Output-current	I ₀ 1,3 mA
Output-power (trapezoidal characteristic)	P ₀ 9,6 mW
Input-voltage	U _i 26 V
Input-current	I _i 113 mA
Input-power	P _i 660 mW
Max. internal capacity	C _i 1 nF
Max. internal inductivity	L _i 240 nH
Max. external capacity, IIB / IIIC	C ₀ 667 nF
Max. external capacity, IIC	C ₀ 85 nF
Max. external inductivity, IIB / IIIC	L ₀ 200 mH
Max. external inductivity, IIC	L ₀ 100 MH
continue on next page	

Output circuit (sensor supply). ST125M*-Ex, only. Terminals 51(+) and 52(-)	
Output-voltage	U _O 25,9 V
Output-current	I _O 92,6 mA
Output-power (linear characteristic)	P _O 598 mW
Max. internal capacity	C _i 1 nF
Max. internal inductivity	L _i 240 nH
Max. external capacity, IIB / IIIC	C _O 769 nF
Max. external capacity, IIC	C _O 99 nF
Max. external inductivity, IIB / IIIC	L _O 8 mH
Max. external inductivity, IIC	L _O 2 mH

Table 16 Technical data potential explosive atmospheres

6.2 Mechanical design / dimensions

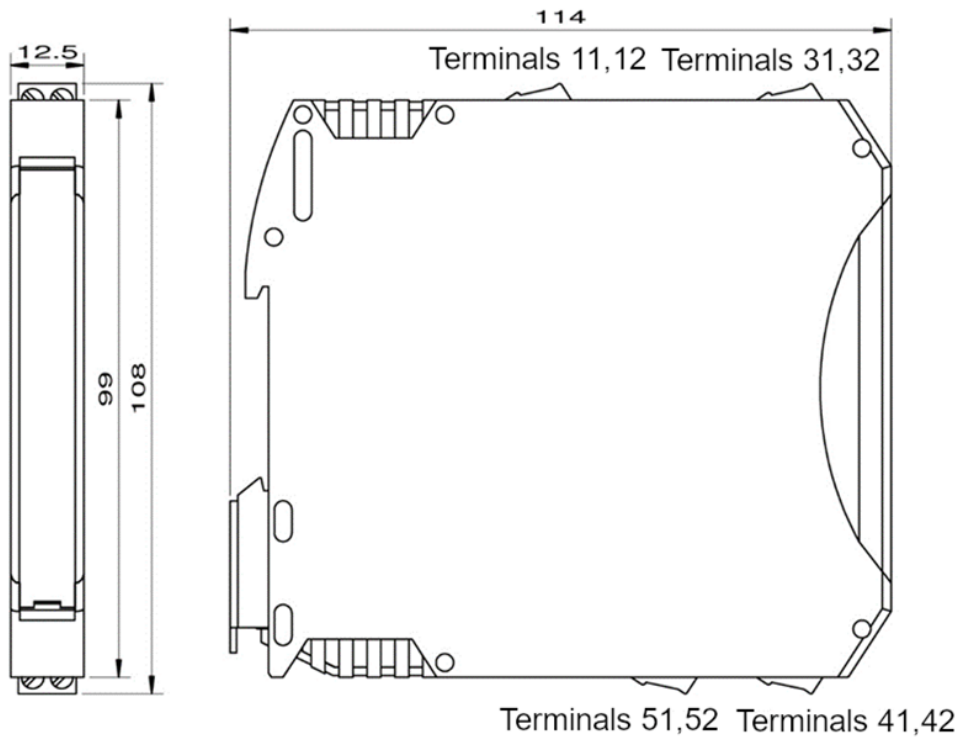

Figure 10 Dimensions

7 Accessories and replacement

Ordering code	Description
PRVK	Power Rail, power connecting terminal side of installation: left

8 Order code

1.		2.		3.		4.	
	-		-		-		

1.	Device Type	
	TV125M	Wide-range power supply 20..125 V DC / 85..253 V AC
	TV125MP	Power supply 24 V DC +/- 15 % via rail mounted connecting terminal (Power Rail)
	ST125M	Transmitter power supply, wide-range power supply 20..125 V DC / 85..253 V AC
	ST125MP	Transmitter power supply, Power supply 24 V DC +/- 15 % via rail mounted connecting terminal (Power Rail)
2.	Explosion protection	
	00	No intrinsically safe input and no intrinsically safe transmitter power supply. The devices TV125MP and ST125MP may be installed in Zone 2 acc. to ATEX-ignition type "ec".
	Ex	In case of installing the devices out of the ex-zone: Input and transmitter feed are intrinsically safe in accordance to ignition protection type "ia" for zones 0 and 20. The devices TV125MP and ST125MP may be installed in Zone 2 acc. to ATEX-ignition type "ic".
3.	Input	
	10	0/2...10 V / 0/4...20 mA
4.	Options	
	00	Without options
	01	Push-in terminals (plug-in)

Table 17 Odering Code

9 Device transport and storage

Gentle and tension-free packaging of the housing must be ensured for transport (no machine wrapping of the package). The device must be stored in the environmental conditions specified in the technical data

10 Returns



Danger!

The legal regulations for environmental protection and our personnel require that devices which are sent back which have come into contact with liquid are handled without risk to people or the environment.

If you send a device back to us for inspection or repair, we must request that you strictly observe the following requirements:

On the Senseca Germany homepage www.senseca.com a return shipment form can be downloaded.

The repair can be performed quickly and without call-back questions if:

1. a filled-in form is provided for each device,
2. the device has been cleaned and packaging which prevents damage to the device is used.

11 Disposal



Separation by material and recycling of device components and packaging must take place when the device is disposed of. The valid legal regulations and directives applicable at the time must be observed.

The device may not be disposed of with household waste. If the device should be disposed of, return it to us with the return shipment form filled in under section 8. We will then arrange for the proper disposal.

12 EU-Declaration of conformity

EU-KONFORMITÄTSERKLÄRUNG
EU-DECLARATION OF CONFORMITY

Senseca | Senseca Germany GmbH | Tenter Weg 2-8 | 42897 Remscheid | GERMANY

 Dokument-Nr. / Monat.Jahr: **2043 / 01.2024**
 Document-No. / Month.Year:

Wir erklären hiermit unter alleiniger Verantwortung, dass die folgenden Produkte konform sind mit den Schutzziele der Richtlinie des Europäischen Parlaments:

We declare herewith under our sole responsibility that the following products are in compliance with the protection requirements defined in the European Council directives:

 Produktbezeichnung: **TV125M-00 / TV125MP-00**
 Product identifier: **ST125M-00 / ST125MP-00**

 Produktbeschreibung: **Trennverstärker**
 Product description: **Isolating signal converter**

 Die Produkte entsprechen den folgenden Europäischen Richtlinien:
 The products conforms to following European directives:

Richtlinien / Directives	
2014/30/EU	EMV-Richtlinie / EMC directive
2014/35/EU	Niederspannungsrichtlinie / Low Voltage Directive
2011/65/EU	RoHS / RoHS

 Angewandte harmonisierte Normen oder angeführte technische Normen:
 Applied harmonized standards or mentioned technical specifications:

Harmonisierte Normen / harmonized standards	
EN 61326-1:2013	Allgemeine EMV-Anforderungen / General EMC requirements
EN 61010-1:2010+A1:2019+A1:2019/AC:2019	Allgemeine Isolationsanforderungen / General isolating requirements
EN IEC 63000:2018	Beschränkung der gefährlichen Stoffe / Restriction of hazardous substances

 Diese Erklärung wird verantwortlich für den Hersteller abgegeben durch:
 The manufacturer is responsible for the declaration released by:

 Walter Vogelsberger
 Senior Director Research & Development

Remscheid, 02. Januar 2024

Diese Erklärung bescheinigt die Übereinstimmung mit den genannten Harmonisierungsrechtsvorschriften, beinhaltet jedoch keine Zusicherung von Eigenschaften

This declaration certifies the agreement with the harmonization legislation mentioned, contained however no warranty of characteristics.



EU-KONFORMITÄTSERKLÄRUNG
EU-DECLARATION OF CONFORMITY

Senseca | Senseca Germany GmbH | Tenter Weg 2-8 | 42897 Remscheid | GERMANY

Dokument-Nr. / Monat.Jahr: **2098 / 01.2024**
Document-No. / Month.Year:

Wir erklären hiermit unter alleiniger Verantwortung, dass die folgenden Produkte konform sind mit den Schutzziele der Richtlinie des Europäischen Parlaments:

We declare herewith under our sole responsibility that the following products are in compliance with the protection requirements defined in the European Council directives:

Produktbezeichnung: **TV125M-Ex / TV125MP-Ex**
Product identifier: **ST125M-Ex / ST125MP-Ex**

Produktbeschreibung: **Speisetrenner / Trennverstärker**
Product description: **Isolating signal converter**

Die Produkte entsprechen den folgenden Europäischen Richtlinien:

The products conforms to following European directives:

Richtlinien / Directives	
2014/30/EU	EMV-Richtlinie / <i>EMC directive</i>
2014/34/EU	ATEX-Richtlinie / <i>ATEX Directive</i>
2014/35/EU	Niederspannungsrichtlinie / <i>Low Voltage Directive</i>
2011/65/EU	RoHS / <i>RoHS</i>

Angewandte harmonisierte Normen oder angeführte technische Normen:

Applied harmonized standards or mentioned technical specifications:

Harmonisierte Normen / <i>harmonized standards</i>	
EN 61326-1:2013	Allgemeine EMV-Anforderungen / <i>General EMC requirements</i>
EN IEC 61326-3-1:2017	Besondere EMV-Anforderungen / <i>Particular EMC requirements</i>
EN IEC 60079-0:2018	Allgemeine Anforderungen / <i>General requirements</i>
EN 60079-7:2015	Geräteschutz durch erhöhte Sicherheit / <i>Protection by increased safety</i>
EN 60079-11:2012	Geräteschutz durch Eigensicherheit / <i>Protection by intrinsic safety</i>
EN 61010-1:2010+ A1: 2019+A1:2019/AC:2019	Allgemeine Isolationsanforderungen / <i>General isolating requirements</i>
EN IEC 63000:2018	Beschränkung der gefährlichen Stoffe / <i>Restriction of hazardous substances</i>

EG-Baumusterprüfbescheinigung / ausgestellt von: **BVS 16 ATEX E 126** / DEKRA EXAM GmbH

EC Type Examination Certificate / issued by:

(Reg.No. 0158)

Qualitätssicherung / *quality assurance:*

DEKRA Testing and Certification GmbH (Reg.No. 0158)

Diese Erklärung wird verantwortlich für den Hersteller abgegeben durch:

The manufacturer is responsible for the declaration released by:

Walter Vogelsberger
Senior Director Research & Development

Reimscheid, 02. Januar 2024

Diese Erklärung bescheinigt die Übereinstimmung mit den genannten Harmonisierungsrechtsvorschriften, beinhaltet jedoch keine Zusicherung von Eigenschaften

This declaration certifies the agreement with the harmonization legislation mentioned, contained however no warranty of characteristics.

senseca.com



Senseca Germany GmbH
Tenter Weg 2-8
42897 Remscheid
GERMANY
INFO@SENSECA.COM

